

TECHNICAL DETAILS

Precast Wall Panels



APPLICABLE FOR:

RESIDENTIAL
COMMERCIAL
CIVIL
INDUSTRIAL
INSTITUTIONAL
AGRICULTURAL



FRITZ-ALDER

P R E C A S T

Why Choose Complete Precast Solutions?

Because no two precast projects are the same

Precast walls are durable and resistant to impact and natural elements (mold, fire, and high winds). Wall panels are 100% customizable - shaped, sized and finished to meet any need.

The Fritz-Alder Advantage

You need a precaster with significant experience in both the specialized areas of fabrication and installation. We have been doing just that in Ontario since 1972, working with some of the most prominent designers, and meeting the requirements of the most exacting customers.

Unique finishes to customize your project

With precast, there are infinite versatile options when it comes to colours and textures to customize a unique finish for your building. Brick, stone, ribbed, stained, textured or smooth, there are hundreds of molds to choose from.

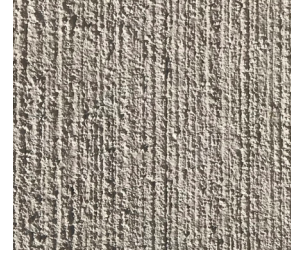
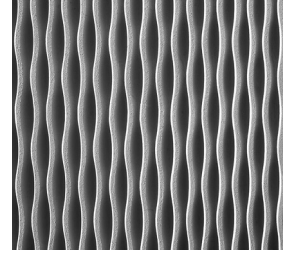
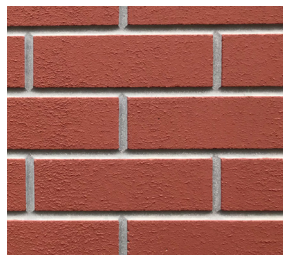

Benefits of Precast

- **Speed of Construction:** Your building gets erected much quicker than other building systems. And, when the structure is complete, so is your façade, saving even more time on your schedule.
- **Strength and Durability:** Precast concrete is virtually maintenance-free, providing a versatile and resilient solution for the long-term demands of your building structures. I
- **Sound Resistant:** Precast concrete acts as a natural sound barrier, making for more quiet, comfortable living spaces.
- **Controlled Casting Conditions:** Casting concrete in a climate-controlled environment ensures a consistent finish and high-quality, precise product.
- **One Supplier:** The Fritz-Alder Precast team provides the product and installation, eliminating the need for multiple trades on site.
- **All-weather Installation:** Precast provides a key construction schedule advantage, as it can be installed in cold weather.

PRECAST WALLS - Connections to Architectural Walls (Cladding)

1
CW

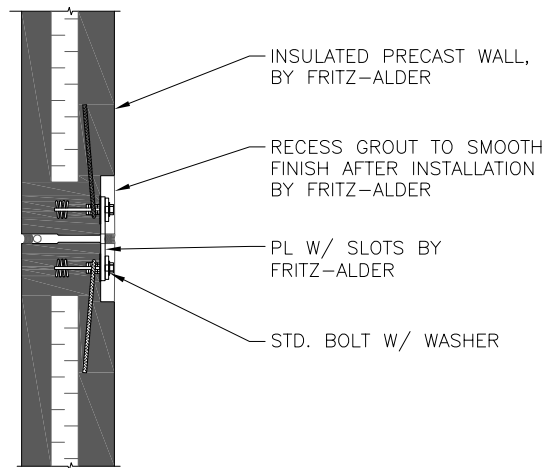

2
CW

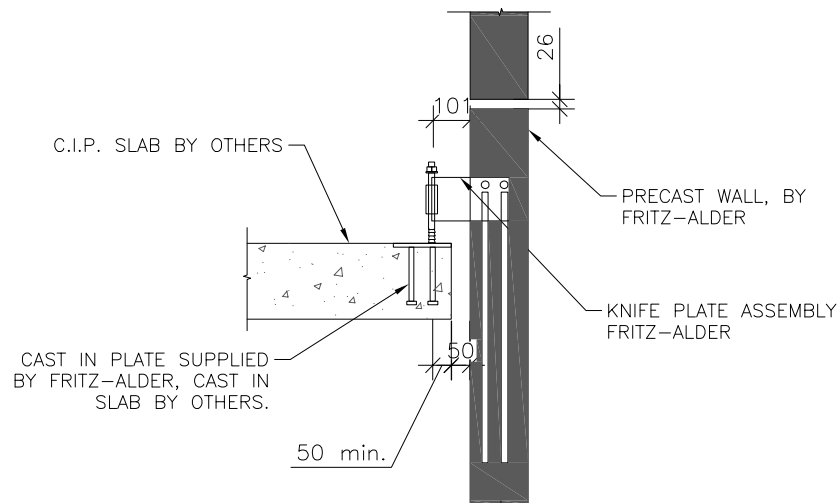

These details are prepared by Fritz-Alder Precast based on industry best practices and standards; however all details shall be verified and approved by E.O.R. prior to use in projects as details may differ for specific projects. Any post applied connection/coring/modifications shall be verified and approved by the qualified professional engineer. For any post applied connection/modification, the actual location of strand/steel reinforcement must be found via proper testing procedures on site. In any circumstances, strand/steel rebars shall not be cut/affected. If any deviation from the detail is required, please call Fritz-Alder Precast for assistance.

PRECAST WALLS - Connections to Architectural Walls (Cladding)

3
CW

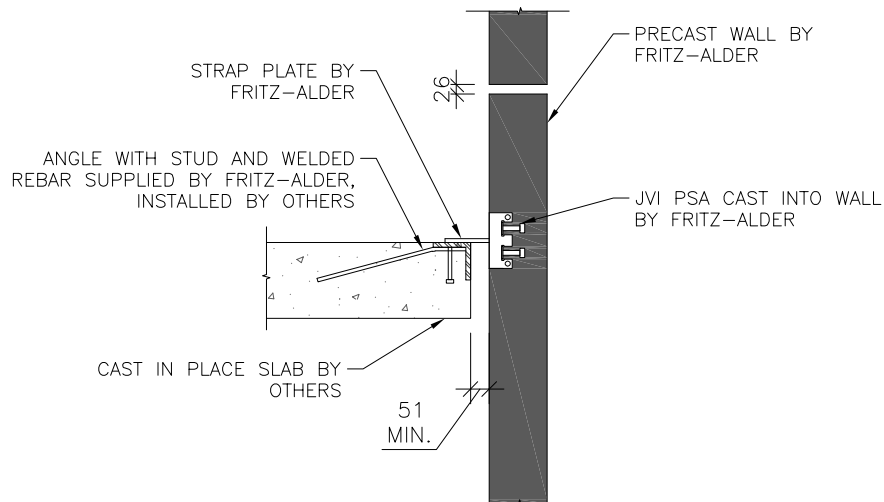

4
CW

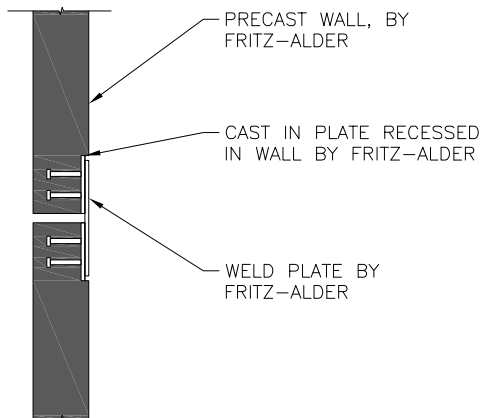

These details are prepared by Fritz-Alder Precast based on industry best practices and standards; however all details shall be verified and approved by E.O.R. prior to use in projects as details may differ for specific projects. Any post applied connection/coring/modifications shall be verified and approved by the qualified professional engineer. For any post applied connection/modification, the actual location of strand/steel reinforcement must be found via proper testing procedures on site. In any circumstances, strand/steel rebars shall not be cut/affected. If any deviation from the detail is required, please call Fritz-Alder Precast for assistance.

PRECAST WALLS - Connections to Architectural Walls (Cladding)

5
CW

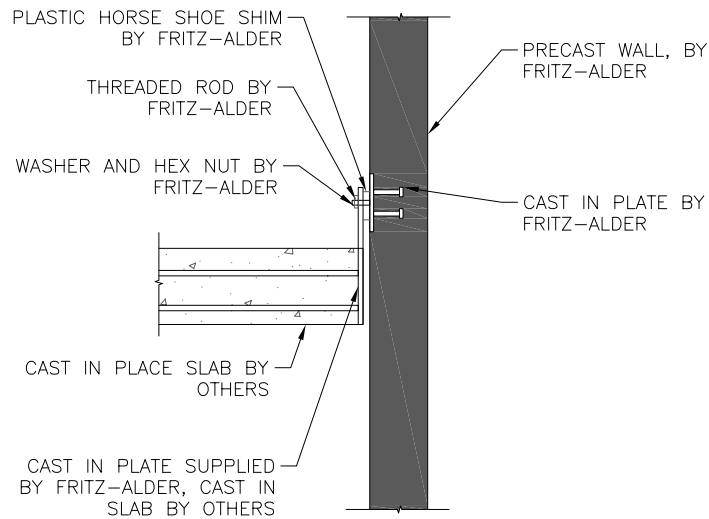

6
CW

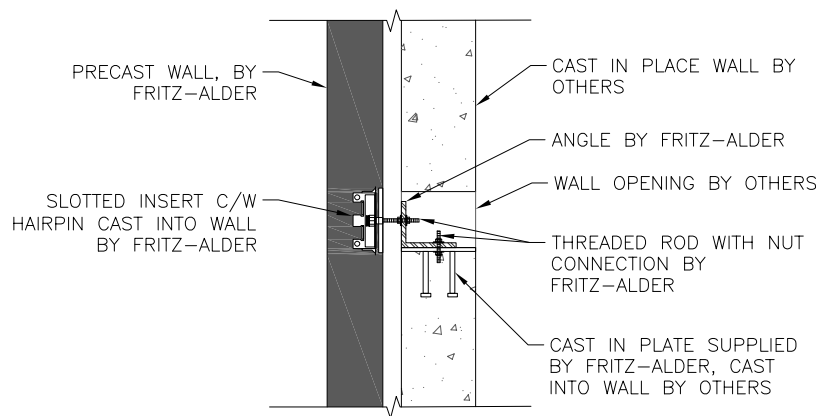

These details are prepared by Fritz-Alder Precast based on industry best practices and standards; however all details shall be verified and approved by E.O.R. prior to use in projects as details may differ for specific projects. Any post applied connection/coring/modifications shall be verified and approved by the qualified professional engineer. For any post applied connection/modification, the actual location of strand/steel reinforcement must be found via proper testing procedures on site. In any circumstances, strand/steel rebars shall not be cut/affected. If any deviation from the detail is required, please call Fritz-Alder Precast for assistance.



FRITZ-ALDER
P R E C A S T

Sales & Engineering: 617 Colby Dr Unit 1, Waterloo, ON N2V 1Y9
Production: 173 Concession 6, Chepstow, ON NOG 1K0
Email: info@faprecast.ca **Phone:** 519-888-8354 **Web:** faprecast.ca

PRECAST WALLS - Connections to Architectural Walls (Cladding)

7
CW

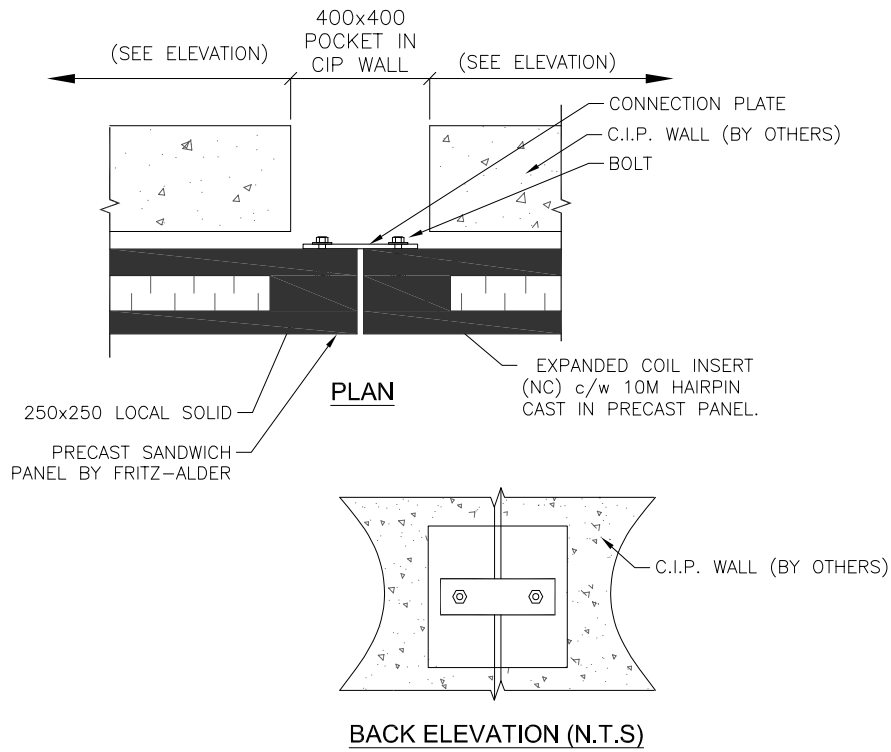

8
CW

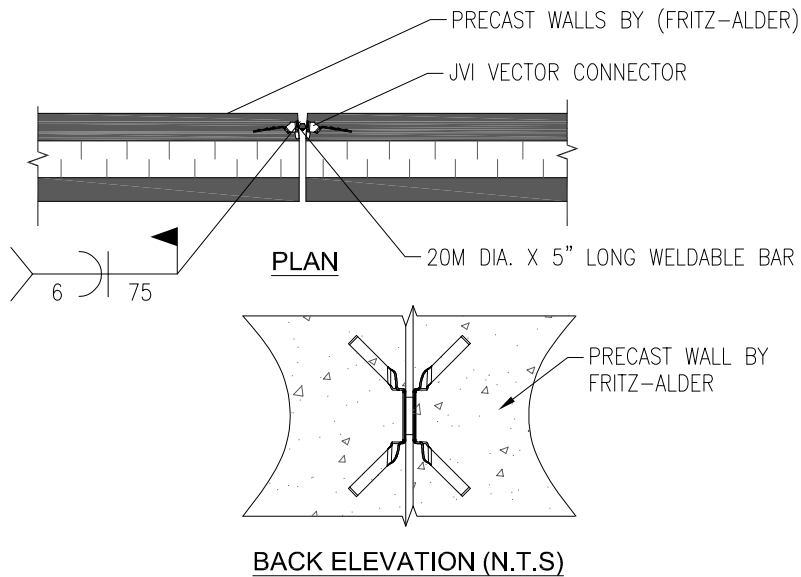

These details are prepared by Fritz-Alder Precast based on industry best practices and standards; however all details shall be verified and approved by E.O.R. prior to use in projects as details may differ for specific projects. Any post applied connection/coring/modifications shall be verified and approved by the qualified professional engineer. For any post applied connection/modification, the actual location of strand/steel reinforcement must be found via proper testing procedures on site. In any circumstances, strand/steel rebars shall not be cut/affected. If any deviation from the detail is required, please call Fritz-Alder Precast for assistance.



FRITZ-ALDER
P R E C A S T

Sales & Engineering: 617 Colby Dr Unit 1, Waterloo, ON N2V 1Y9
Production: 173 Concession 6, Chepstow, ON NOG 1K0
Email: info@faprecast.ca **Phone:** 519-888-8354 **Web:** faprecast.ca

PRECAST WALLS - Connections to Architectural Walls (Cladding)

9
CW

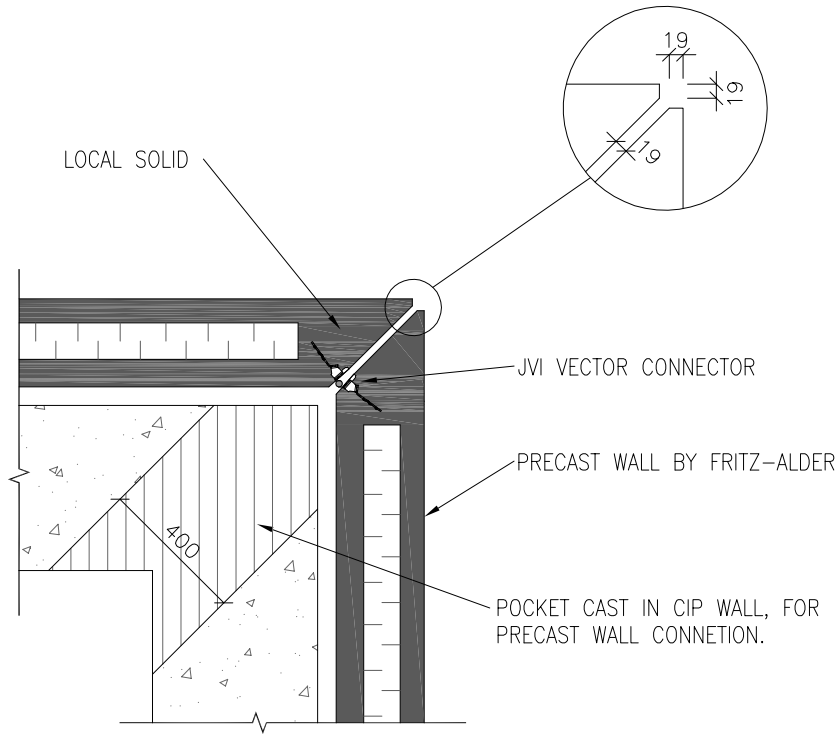

10
CW

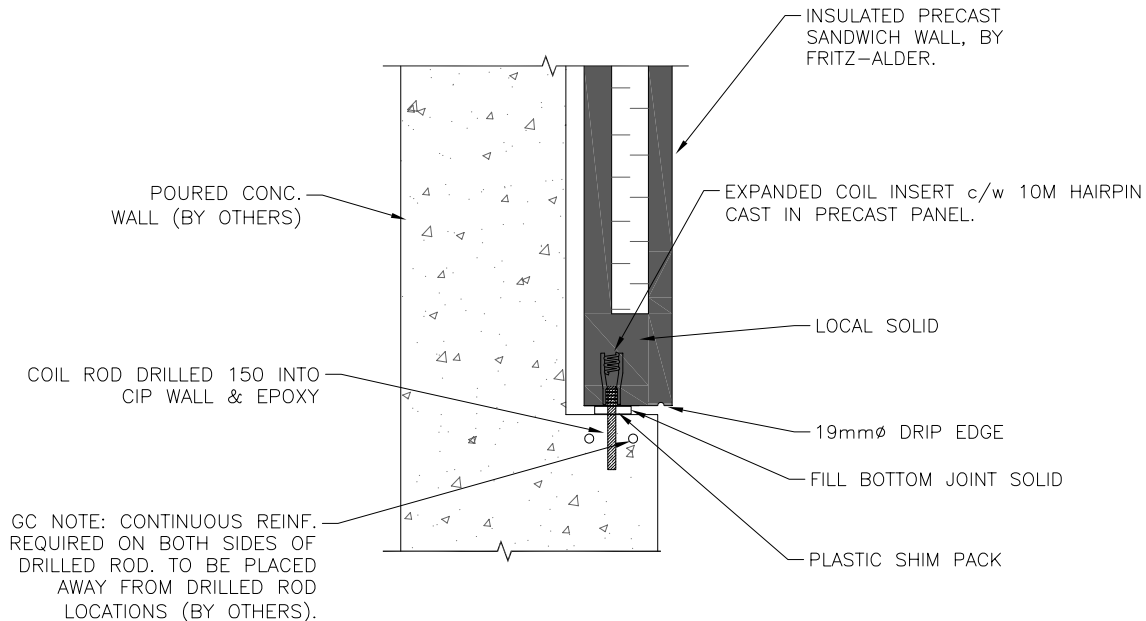

These details are prepared by Fritz-Alder Precast based on industry best practices and standards; however all details shall be verified and approved by E.O.R. prior to use in projects as details may differ for specific projects. Any post applied connection/coring/modifications shall be verified and approved by the qualified professional engineer. For any post applied connection/modification, the actual location of strand/steel reinforcement must be found via proper testing procedures on site. In any circumstances, strand/steel rebars shall not be cut/affected. If any deviation from the detail is required, please call Fritz-Alder Precast for assistance.



FRITZ-ALDER
P R E C A S T

Sales & Engineering: 617 Colby Dr Unit 1, Waterloo, ON N2V 1Y9
Production: 173 Concession 6, Chepstow, ON NOG 1K0
Email: info@faprecast.ca **Phone:** 519-888-8354 **Web:** faprecast.ca

11
CW

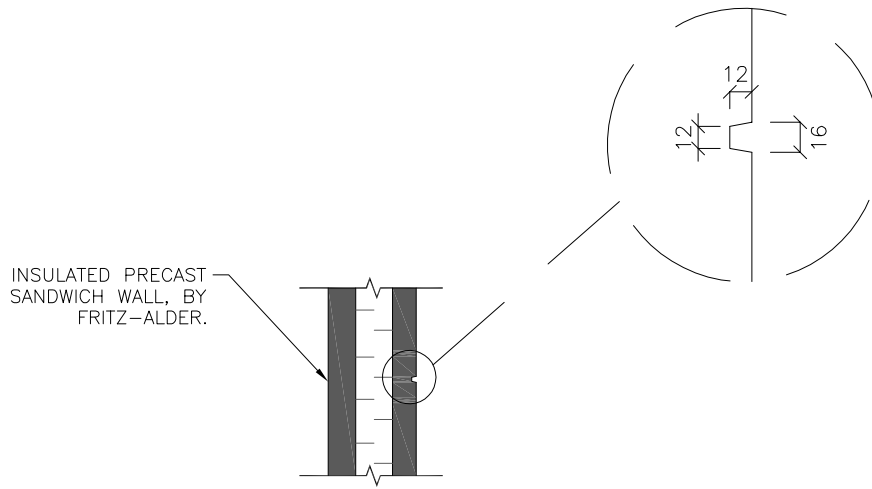

These details are prepared by Fritz-Alder Precast based on industry best practices and standards; however all details shall be verified and approved by E.O.R. prior to use in projects as details may differ for specific projects. Any post applied connection/coring/modifications shall be verified and approved by the qualified professional engineer. For any post applied connection/modification, the actual location of strand/steel reinforcement must be found via proper testing procedures on site. In any circumstances, strand/steel rebars shall not be cut/affected. If any deviation from the detail is required, please call Fritz-Alder Precast for assistance.



FRITZ-ALDER
P R E C A S T

Sales & Engineering: 617 Colby Dr Unit 1, Waterloo, ON N2V 1Y9
Production: 173 Concession 6, Chepstow, ON NOG 1K0
Email: info@faprecast.ca **Phone:** 519-888-8354 **Web:** faprecast.ca

PRECAST WALLS - Connections to Industrial Walls

1
IW

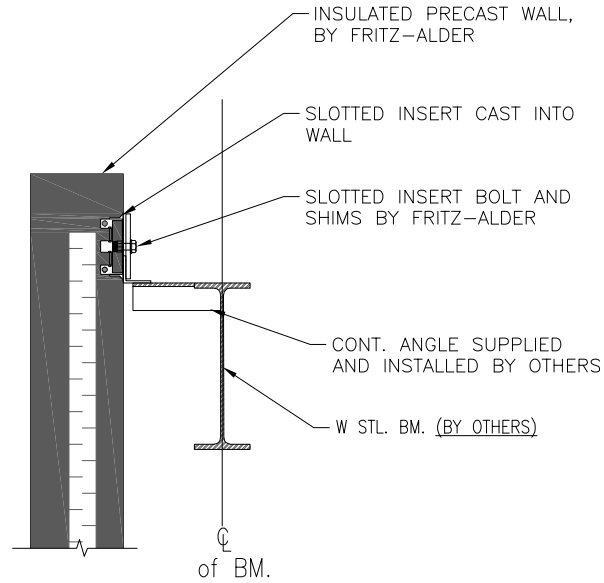

2
IW

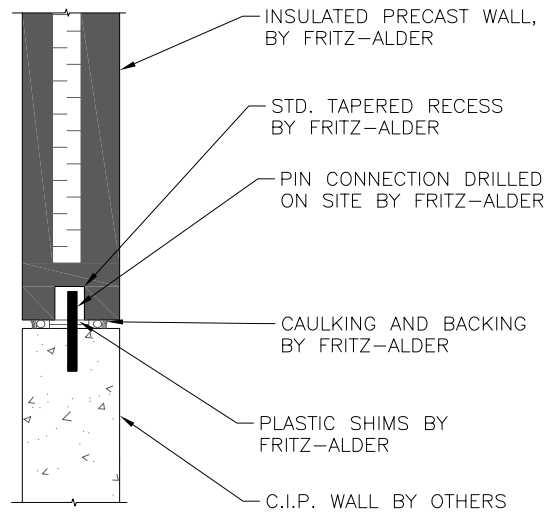

These details are prepared by Fritz-Alder Precast based on industry best practices and standards; however all details shall be verified and approved by E.O.R. prior to use in projects as details may differ for specific projects. Any post applied connection/coring/modifications shall be verified and approved by the qualified professional engineer. For any post applied connection/modification, the actual location of strand/steel reinforcement must be found via proper testing procedures on site. In any circumstances, strand/steel rebars shall not be cut/affected. If any deviation from the detail is required, please call Fritz-Alder Precast for assistance.



FRITZ-ALDER
P R E C A S T

Sales & Engineering: 617 Colby Dr Unit 1, Waterloo, ON N2V 1Y9
Production: 173 Concession 6, Chepstow, ON NOG 1K0
Email: info@faprecast.ca **Phone:** 519-888-8354 **Web:** faprecast.ca